

SHELBY CONSOLIDATED SOUTHEAST DRAIN
INTRA-COUNTY DRAINAGE BOARD
NOVEMBER 14, 2022
11:00 A.M.
AGENDA

**NOTE: THIS MEETING WILL BE HELD IN PERSON WITH TELECONFERENCE
OPTION FOR PUBLIC**

**Call in Number: 1-307-314-3902
Access Code: 199 831 865**

	Page
1. Call of meeting to order and roll call	
2. Approval of Agenda for November 14, 2022	
3. Approval of Minutes for October 15, 2018	3
4. Public Participation	
5. CMP Failure Repair – Julie Ann Court – Stephen Downing	5
Motion: To authorize the needed repairs to the sinkhole at the lowest contractor quote at an amount not to exceed \$60,700.	
6. Financial Report – Bruce Manning	14
7. Adjourn	

SHELBY CONSOLIDATED DRAIN - SOUTHEAST SECTION & BRANCHES

MACOMB TOWNSHIP/SHELBY TOWNSHIP/UTICA

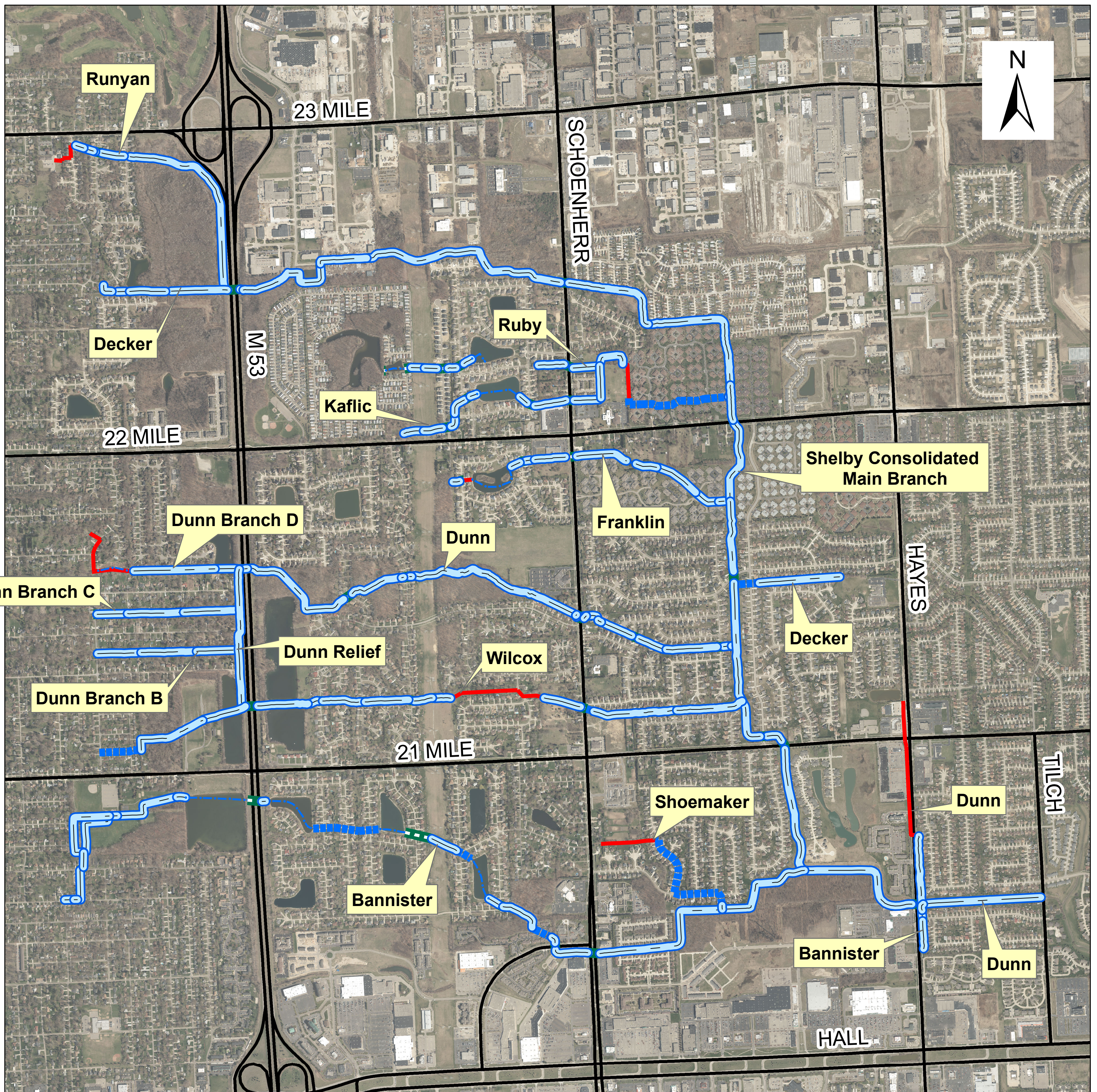

Legend



Drain Length (Feet/Miles):
105,774.79 / 20.03

Enclosed Gravity	Open Channel
< 60" Dia	Ditch
>= 60" Dia	Pond
Culvert	



An adjourned meeting of the Intra-County Drainage Board for the **SHELBY CONSOLIDATED DRAIN – SOUTHEAST** was held in the Office of the Macomb County Public Works Commissioner, 21777 Dunham, Clinton Township, Michigan, on October 15, 2018, at 10:37 A.M.

PRESENT: Candice S. Miller, Chair
Bryan Santo, Member
James Carabelli, Member

ALSO PRESENT: Veronica Klinefelt, Robert Leonetti, Macomb County Board of Commissioners; Brian Baker, Chief Deputy, Karen Czernel, Deputy, Vincent Astorino, Operations and Flow Manager, Evans Bantios, P.E., Construction and Maintenance Manager, Jeff Bednar, P.E., Environmental Resources Manager, Bruce Manning, Financial Manager, Dan Heaton, Public Relations Manager, Thomas Stockel, Construction Engineer, Barbara Delecke, Administrative Services, Macomb County Public Works (MCPW); Jordan Scott, Sterling Heights Public Works Department, Chris Dilbert, President, Village of New Haven

The meeting was called to order by the Chair, Candice Miller. A motion was made by Mr. Santo, supported by Mr. Carabelli to approve the agenda as presented.

Minutes of the meeting of August 13, 2018 were presented. A motion was made by Mr. Carabelli, supported by Mr. Santo as presented.

Adopted: YEAS: 3
NAYS: 0

The meeting was opened to public participation, then closed, there being no comments from the public.

The Chair presented the invoice totaling \$5,437.50 to the board for review and approval.

A motion was made by Mr. Santo, supported by Mr. Carabelli to approve the invoice as presented.

Adopted: YEAS: 3
NAYS: 0

A motion to receive and file the financial report given by Mr. Manning was made by Mr. Carabelli and supported by Mr. Santo.

Adopted: YEAS: 3
NAYS: 0

There being no further business, it was moved by Mr. Carabelli, supported by Mr. Santo, that the meeting of the Shelby Consolidated Drain – Southeast Board be adjourned.

Adopted: YEAS: 3
NAYS: 0

The meeting was adjourned at 10:50 a.m.



Candice S. Miller, Chair
Macomb County Public Works Commissioner

STATE OF MICHIGAN
COUNTY OF MACOMB

I certify that the foregoing is a true and correct copy of proceedings taken by the Intra-County Drainage Board for the Drainage District shown on the attached set of minutes, on October 15, 2018, the original of which is on file in the Public Works Commissioner's Office. Public notice of the meeting was given pursuant to Act No. 267, Public Acts of Michigan, 1975, including, in the case of a special or rescheduled meeting or a meeting secured for more than 36 hours, notice by posting at least 18 hours prior to the time set for the meeting.



Candice S. Miller, Chair
Macomb County Public Works Commissioner

DATED: 10/18/18

9487.bd



Candice S. Miller

Public Works Commissioner
Macomb County

To: Shelby Consolidated Drain – Southeast Section Wilcox Branch Drainage District Board Members

From: Stephen Downing, Construction & Maintenance Manager

Date: October 24, 2022

Subject: Sinkhole at 12882 Julie Ann Court - CMP Failure Repair

The Macomb County Public Works Office (MCPWO) staff were made aware of a sinkhole at 12882 Julie Ann Court on the Shelby Consolidated Drain – Southeast Section Wilcox Branch in Shelby Township.

The drain at this location consists of a 30-inch RCP that carries low flow or moderate wet-weather flows and a high flow/overflow elliptical 64 x 43 CMP that carries heavier wet-weather flows. The repair consists of removal and replacement of approximately 64-linear feet of the failing elliptical 64 x 43 CMP with 48-inch RCP and a new 84-inch manhole structure. The MCPWO has received one quotation from Robert Clancy Contracting, Inc. for the amount of \$60,700. Our staff is working to solicit at least two additional quotations for this work prior to proceeding with the repair.

Unfortunately, this is an extremely busy time of the year for Contractors that perform this type of work, which is resulting in slower response time for quotations and in some cases Contractor's are turning down the work. In light of this, the MCPWO is requesting that the Board authorize this work for the Not-to-Exceed amount of \$60,700.00 pending receipt of additional bids that may be less.

The MCPWO is allocating \$20,000 of the County Drain funds toward this repair. The remaining funds required will come from the Drain account.

The recommendation is that the Shelby Consolidated Drain – Southeast Section Wilcox Branch Drainage District Board authorize MCPWO to perform the repairs for the Total Not-to-Exceed amount of \$60,700.00.

Attachments: Project Location
Pictures
Robert Clancy Contracting Quotation

Troubleshooting – Sinkhole Complaint

September 2, 2022



Jim Thomas – 12882 Julie Ann Ct. Phone 586.484.2551

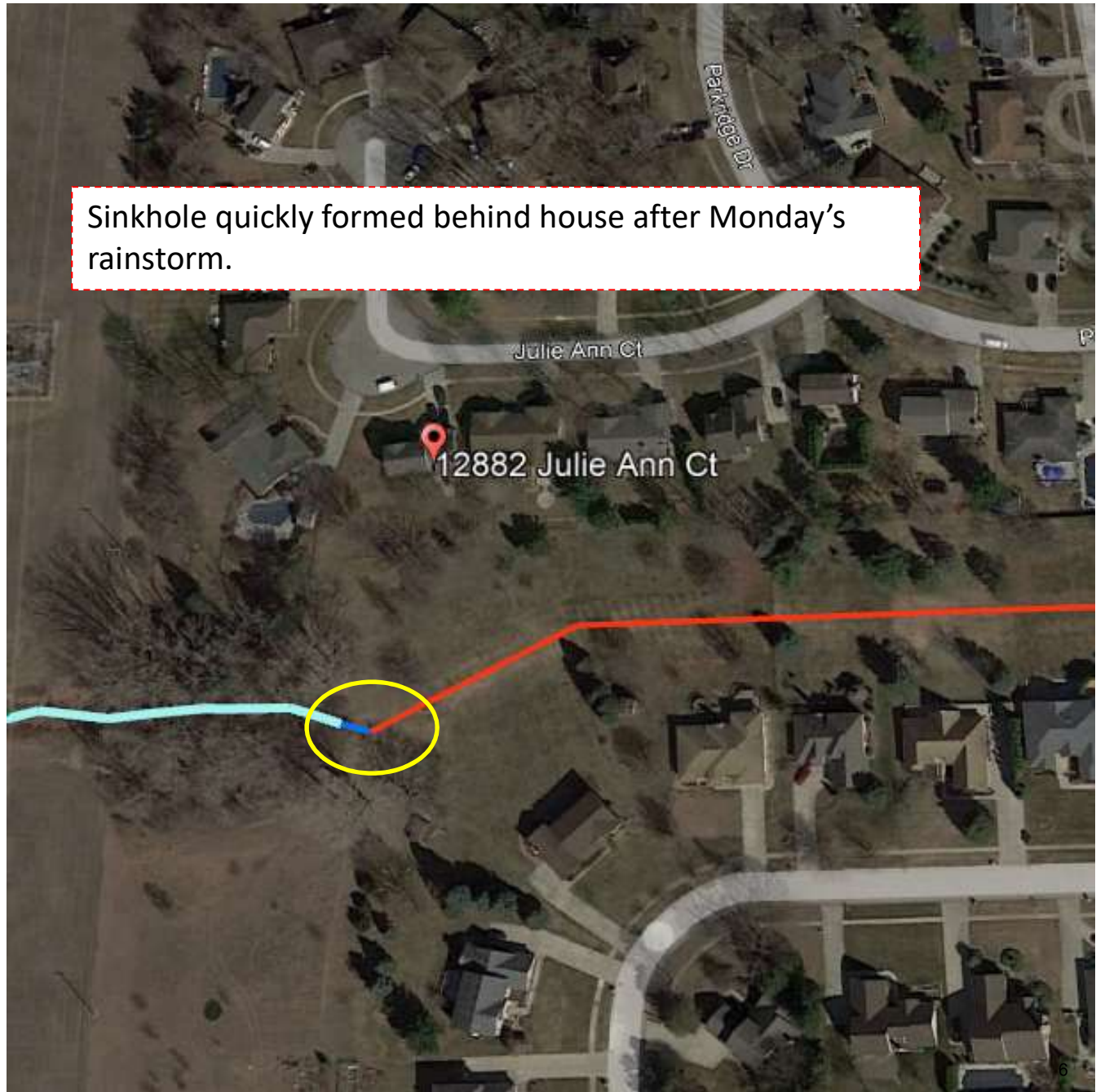

Troubleshooting – Sinkhole Complaint

September 2, 2022



Profile:

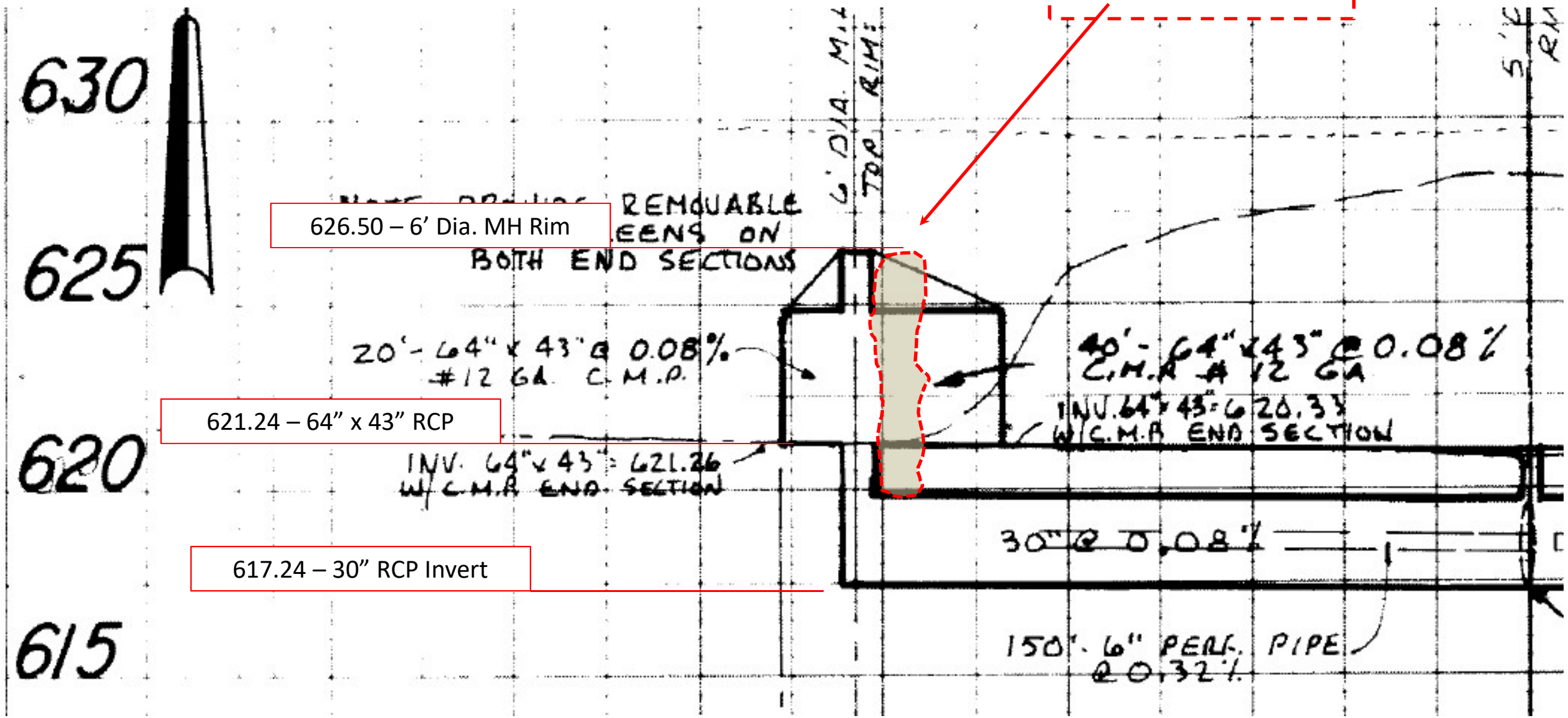

626.50 – 6' Dia. MH Rim

621.24 – 64" x 43" RCP

617.24 – 30" RCP Invert

Troubleshooting - Sinkhole Complaint

September 2, 2022



1989 ish Constructed
(Over 30 Year Old 12 GA. CMP)

Sinkhole Location

I Expect that the 64" x 43" CMP is the problem ! Inspection to Follow !

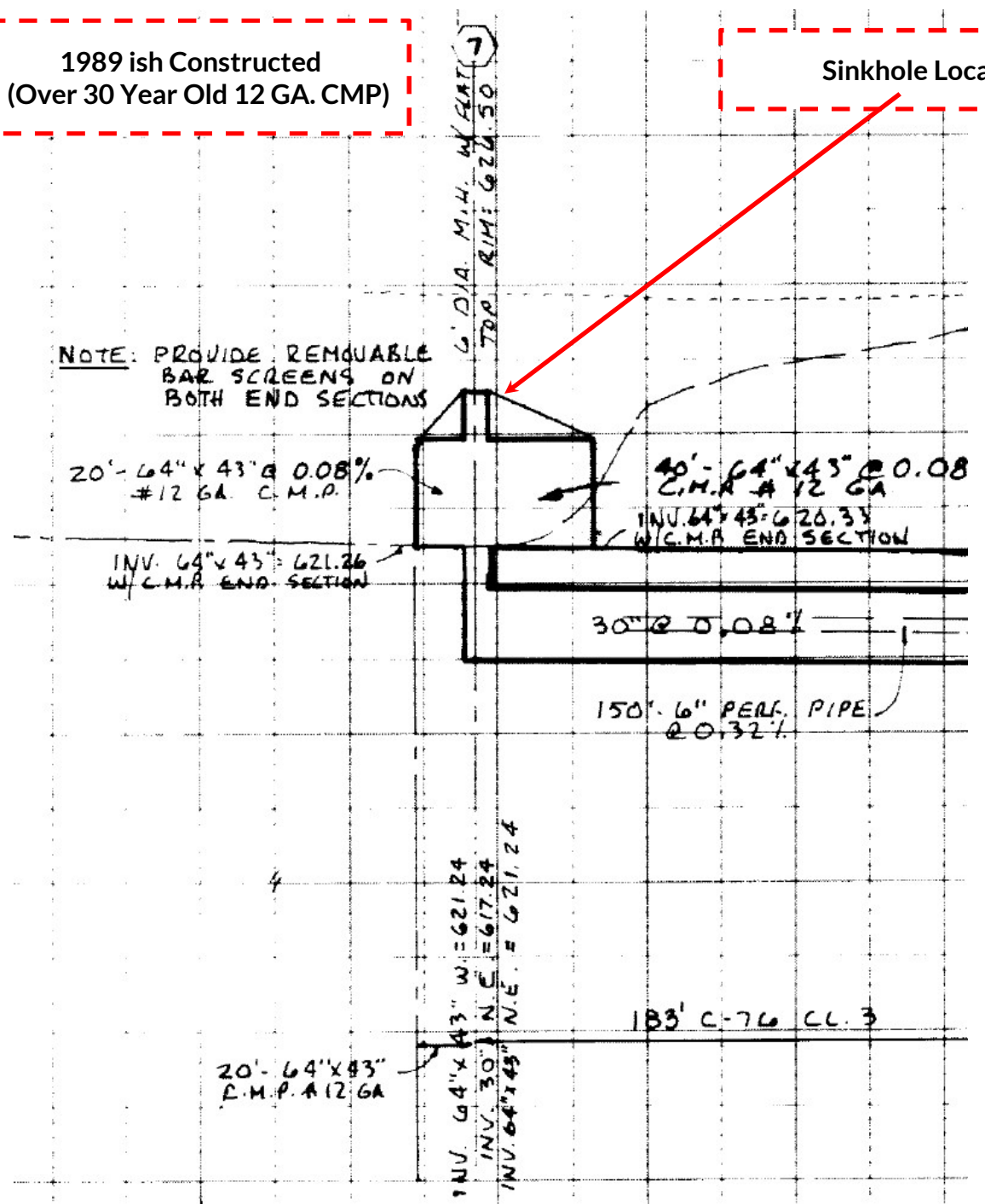

Troubleshooting – Sinkhole Complaint



Appears to be failing Between the CMP and The 30" RCP



Needs a detailed Inspection to determine actual cause.
This Structure needs INSPECTION its goofy ??

Wilcox Branch - # 458 Shelby SE

September 2, 2022 – Site Visit

Troubleshooting – Sinkhole Complaint



Appears to be failing Between the CMP and The 30" RCP

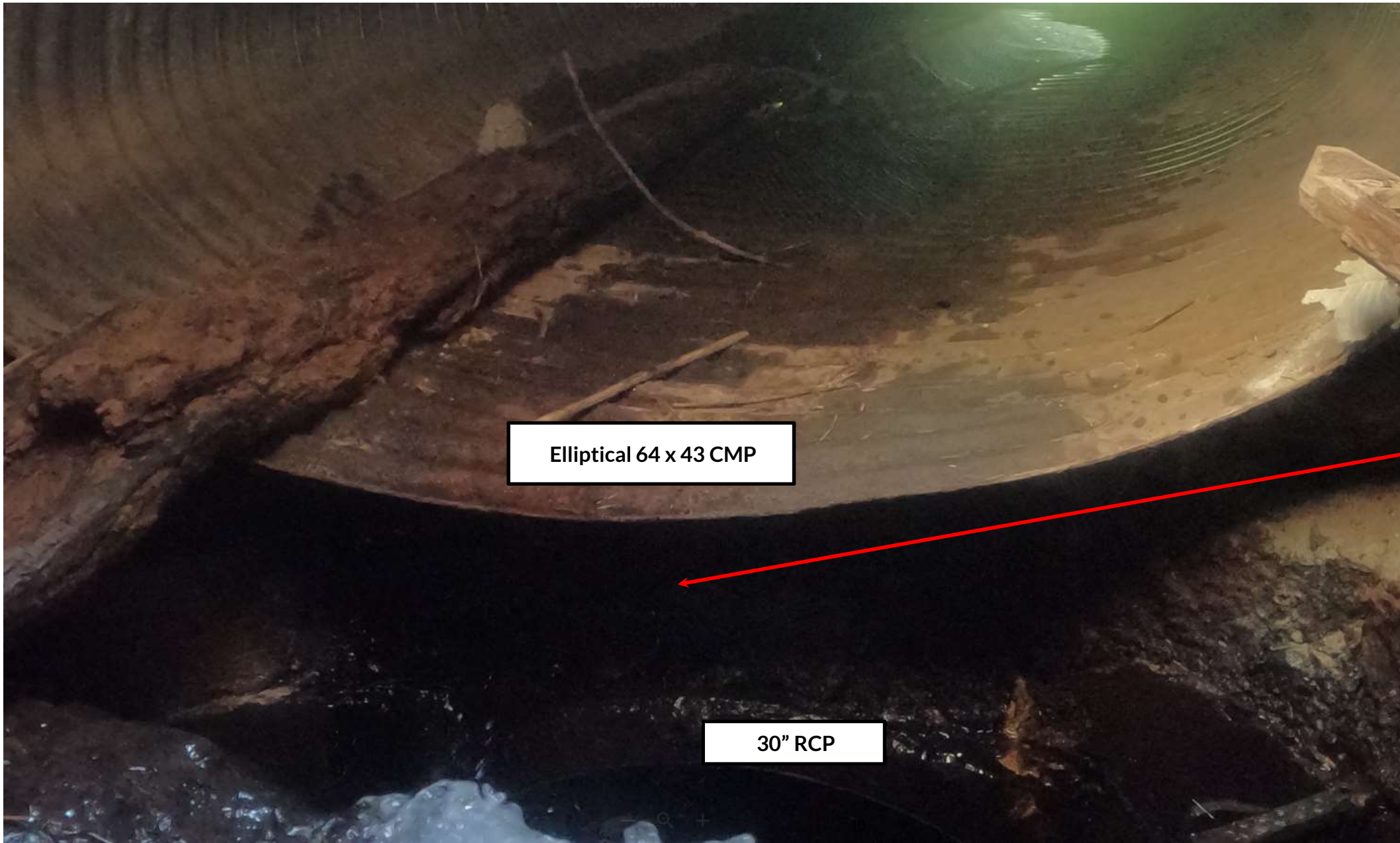

Elliptical 64 x 43 CMP

30" RCP

Maybe Location of issue ?

Wilcox Branch - # 458 Shelby SE

September 2, 2022 – Site Visit

Troubleshooting – Sinkhole Complaint

September 2, 2022



Plan View Detail:

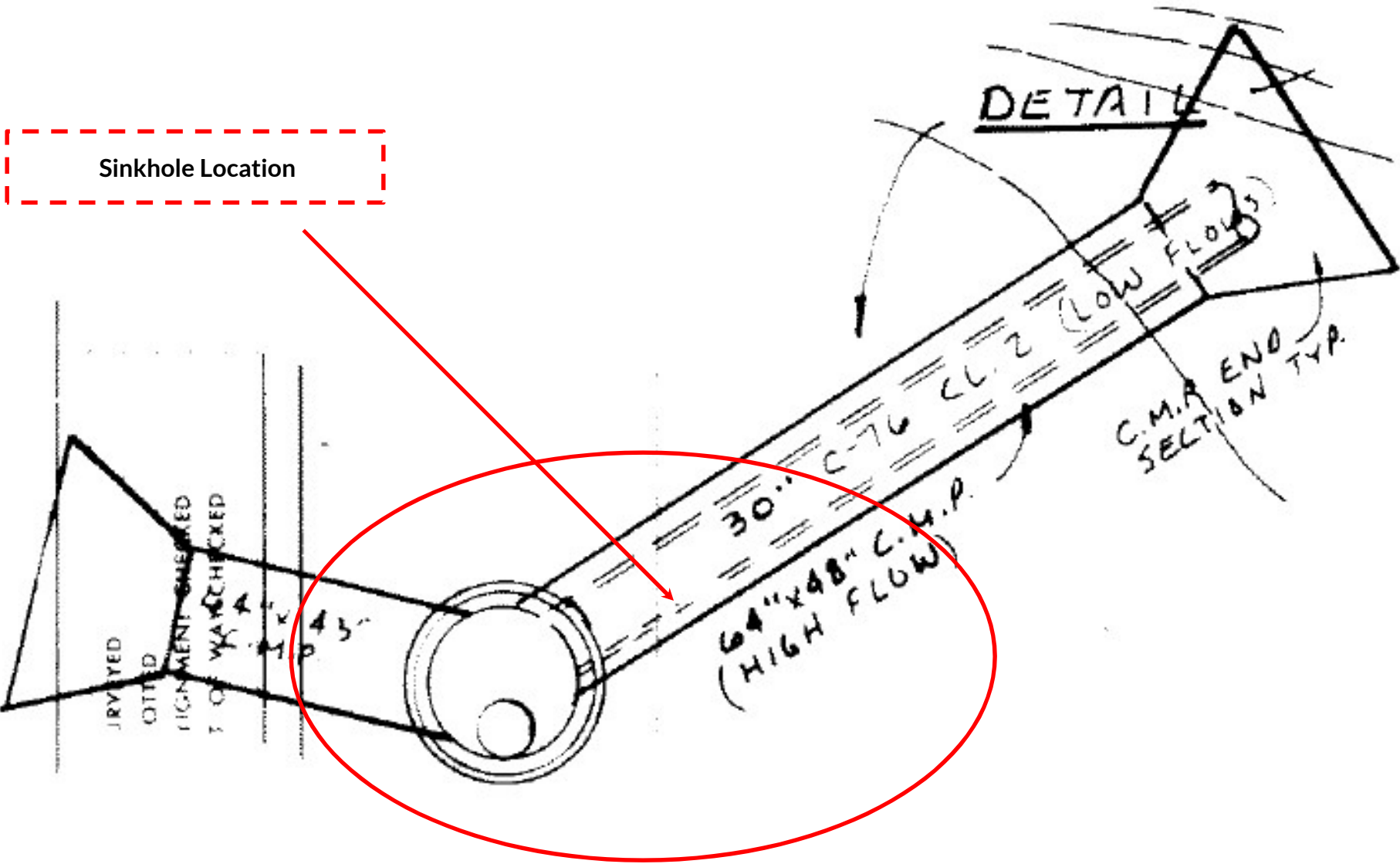

Troubleshooting – Sinkhole Complaint

September 2, 2022



Plan View

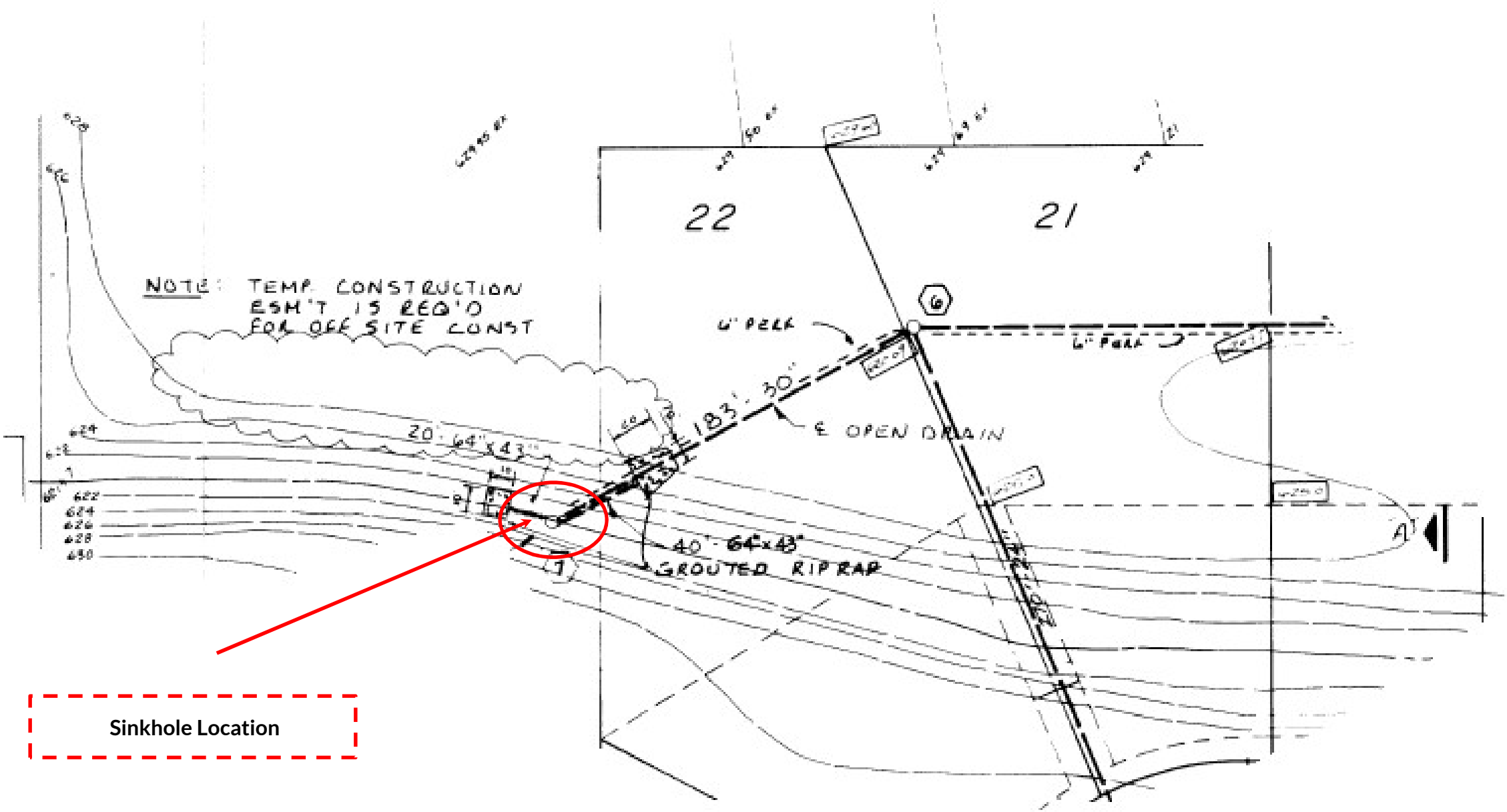

Sinkhole Location



ROBERT CLANCY CONTRACTING, INC.

Proposal

PROPOSAL SUBMITTED TO:		PHONE: 586-615-4198	DATE: 9/27/2022
NAME: Macomb County DPW		FAX:	DWG DATE:
STREET: 21777 Dunham Rd.		JOB NAME: Wilcox Drain	PROPOSAL #: 22108
CITY/STATE: Clinton Twp., MI. 48036		STREET: 12882 Julie Ann Ct	
ATTN: Mr. Tom Stockel		CITY/STATE: Shelby Twp., MI. 48315	

We hereby submit specifications and estimates for:

WATER/FIRE SERVICE AND SITE WORK

	<u>QTY</u>	<u>UM</u>
1.) MOBILIZATION	1	LS
2.) EXCAVATE EXISTING STORM STRUCTURE AND CMP	315	CY
3.) DEMO AND HAUL OFF EXISTING STORM STRUCTURE AND CMP	1	LS
4.) PROVIDE 6A STONE BEDDING	30	TN
5.) PROVIDE AND INSTALL 84" STORM MANHOLE	1	EA
6.) PROVIDE AND INSTALL 48" RCP	64	LF
7.) PROVIDE AND INSTALL 48" CONCRETE FLARED END SECTION	2	EA
8.) INSTALL CONCRETE COLLARS ON CONCRETE PIPE CONNECTIONS	4	EA
9.) BACKFILL WITH ON SITE SPOILS	315	CY
10.) PROVIDE AND PLACE TOP SOIL	30	CY
11.) RESTORATION	1	LS
		Proposal Total: \$ 60,700.00

Exclusions

Permits, bonds and/or inspection fees	Excavation for building foundations	Pavement Restoration
Layout and engineering services	Removal of contaminated spoils	TV testing of sanitary sewer
Stone bedding (unless otherwise stated)	Tree, stump or brush removal or replacement	De-watering
Soil erosion devices (unless otherwise stated)	Curb grade (unless otherwise stated)	Compaction testing
Imported backfill material (unless otherwise stated)	Landscape restoration/Irrigation repair	
	Traffic Control (unless otherwise stated)	

* This proposal is based on the assumption that all soils are non-contaminated. Owner/Developer will be required to furnish RCC with analytical documentation verifying non-contamination of soils.

ALL MATERIAL IS GUARANTEED TO BE AS SPECIFIED. ALL WORK TO BE COMPLETED IN A WORKMANLIKE MANNER ACCORDING TO STANDARD PRACTICE. ANY ALTERATION OR DEVIATION FROM ABOVE SPECIFICATIONS INVOLVING EXTRA COSTS, WILL BE EXECUTED ONLY UPON WRITTEN ORDER, AND WILL BECOME AN EXTRA CHARGE OVER AND ABOVE THE ESTIMATE. ALL AGREEMENTS CONTINGENT UPON STRIKES, ACCIDENTS, OR DELAYS BEYOND OUR CONTROL. OWNER TO CARRY FIRE, TORNADO AND OTHER NECESSARY INSURANCE. OUR WORKERS ARE FULLY COVERED BY WORKERS COMPENSATION INSURANCE.

Authorized Signature: _____

NOTE: THIS PROPOSAL MAY BE WITHDRAWN BY US IF NOT ACCEPTED WITHIN 30 DAYS.

Robert G. Clancy, President

THE ABOVE PRICES, SPECIFICATIONS AND CONDITIONS ARE SATISFACTORY AND ARE HEREBY ACCEPTED. YOU ARE AUTHORIZED TO DO THE WORK AS SPECIFIED. PAYMENT WILL BE MADE AS OUTLINED BELOW.

Payment to be made as follows: Progress Payments

Accepted: _____
Date _____

*A monthly service charge of 1.5% (18% per annum) will be charged to past due balances

Authorized Signature _____

Please Sign, Date and Return Original to Robert Clancy Contracting, Inc. - Retain a Copy for Your Records

YTD Trial Balance

Fund: Shelby Consolidated SE

As of Fiscal Period: Oct 1, 2022-Oct 31, 2022

	O&M Balance 9/30/2022	O&M	Total 9/30/2022
Cash - Operating	335,920	42	335,962
Accounts Receivable			0
Assets			0
Liabilities			0
Revenues		42	42
Expenditures			0
Equity	335,920		335,962